

OIL FREE. DISRUPTED

YOUR ALWAYS BETTER CHOICE IS HERE

**AB SERIES OIL FREE
SCREW AIR COMPRESSORS**



**15 - 150 hp / 27.4 - 560 cfm
11 - 110 kW / 0.77 - 15.9 m³/min**

OILFREE[™]
CLASS-0 ISO 8573-1

Low Cost of Ownership | Zero Process Contamination | 100% Class Zero Air | Low Carbon Footprint

Air quality on your mind?

With a global presence in more than 100 countries and over 2 million installations, ELGi has spearheaded compressed air solutions, creating machines that have altered the way industries function. At ELGi, we believe in enhancing customer experience, producing reliable machines that

add value and improving manufacturing capabilities. With the introduction of the AB 'Always better' series oil free screw air compressors, ELGi brings you a disruption in oil free compressed air technology. If air quality is your priority, then AB Series is your solution.



For over 60 years, ELGi has engineered a technologically superior range of compressed air systems with a promise to be always better.

60

YEARS OF CUSTOMER CENTRIC INNOVATION

2 mn+

INSTALLATIONS WORLDWIDE

120+

COUNTRIES AND COUNTING



DEMING PRIZE 2019

ELGi is the first globally established industrial air compressor manufacturer to be awarded the Deming Prize for Excellence in Total Quality Management.

In the industrial world, compressed air applications are so numerous and diverse that one may come across it every single day.

ELGi, one of the world's leading air-compressor manufacturers, who designs and offers an extensive range of innovative and technologically advanced

compressed air solutions for a variety of industry applications. ELGi has earned worldwide accolades for designing customer-centric compressed air solutions which are sustainable and help companies achieve their productivity goals, while ensuring a lower total cost of ownership.

Oil Free Compressed Air

The new normal!

Industries around the world are endeavouring to reduce their carbon footprint and adhere to international compliance norms.

Air quality is critical for sensitive industries ranging from Food and Beverages, Textiles, Pharmaceuticals, Electronics, Oil and Gas, Metals and Power industries, in which stringent compliance norms mandate contaminant free air.

Oil Free air has become a necessity. Historically companies have suffered the constraints of high cost, poor reliability, and low efficiency in order to have oil free air.

“ELGi AB Series Oil Free Compressor is a perfect solution”

With increasing pollution concerns and stringent environmental regulation, air quality and specifically

APPLICATIONS



FOOD & BEVERAGES



TEXTILES



PHARMACEUTICALS

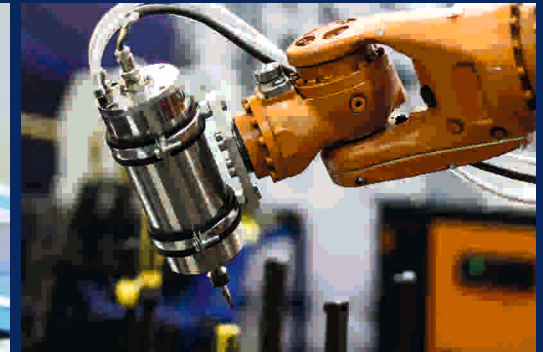

ELECTRONICS



METALS



AUTOMOTIVE



OIL & GAS



POWER



Every year, almost 2 million liters (more than .5 million gallons) of oil is released into the atmosphere. With global climate change and air quality concerns - we're witnessing a rise in collaborative international efforts to reduce the concentration of greenhouse gases and critical pollutants.

OIL FREE. DISRUPTED - AB SERIES

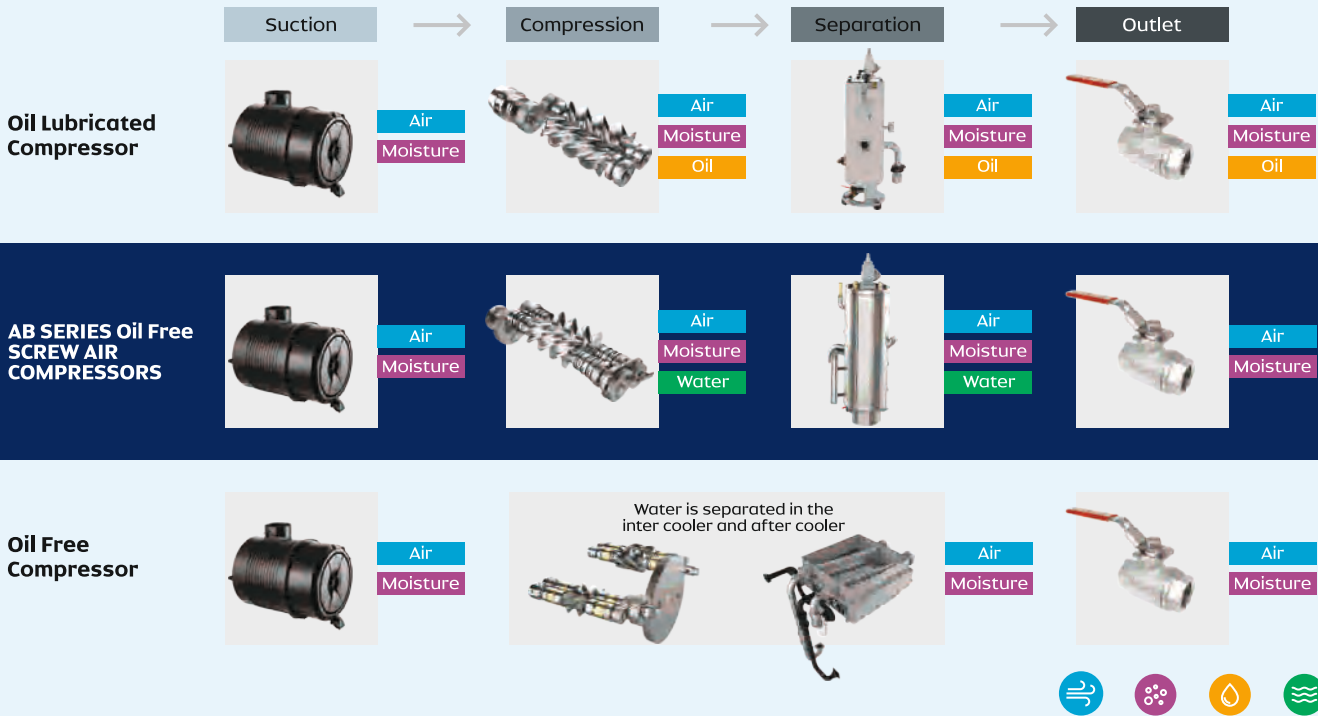

At ELGi, we've re-defined oil free compressor technology and built products that deliver high performance with minimal environmental impact. Today, our oil free compressors support some of the most critical and sensitive applications which demand, not just a high level of air quality, but also zero mineral oil residue.

With the ELGi AB 'Always Better' series, we bring you a disruption in oil free compressed air technology.

LOWER LIFE-CYCLE COSTS

A no-compromise, oil free solution at reduced life cycle costs when compared with prevailing oil free technology.

RELIABILITY

Significantly lower maintenance, peace of mind and ease of use.

AIR QUALITY

Class zero certified, contamination-free air for sensitive industry applications.

Every ELGi AB series customer across the world is assured of zero risk of contamination in the compressed air. Our customers are assured of guaranteed emission reduction while ensuring class zero air, free of oil residue, at all times.

OIL FREE. DISRUPTED

AB 'ALWAYS BETTER' SERIES OIL FREE SCREW AIR COMPRESSORS

ELGi's AB Series compressors deliver 100% oil free air, in compliance with the stringent norms of **ISO 8573 -1 Class 0 and ISO 8573-7**. The result? High quality air, free of microbiological contaminants.

Using an innovative approach to reduce cost and increase efficiency, the ELGi AB series is engineered to deliver maximum uptime and reliability, bridging

the gap between energy efficiency and a low cost of ownership. ELGi's unique rotor design reduces pressure loss, increases stage efficiency, resulting in an optimised compressed air system.

From a design perspective, the AB series is customer centric and reflects our focus on product aesthetics, design and innovation.

The AB series oil free screw compressor incorporates 16 design claims that makes ELGi the 1st in market to introduce this type of compressors with minimum life cycle cost for customers.

BETTER **RELIABILITY** | LOWER **MAINTENANCE COST**
LOWER **LIFE-CYCLE COST** | **SIMPLICITY OF DESIGN**



Why ELGi AB Series is 'Always Better'

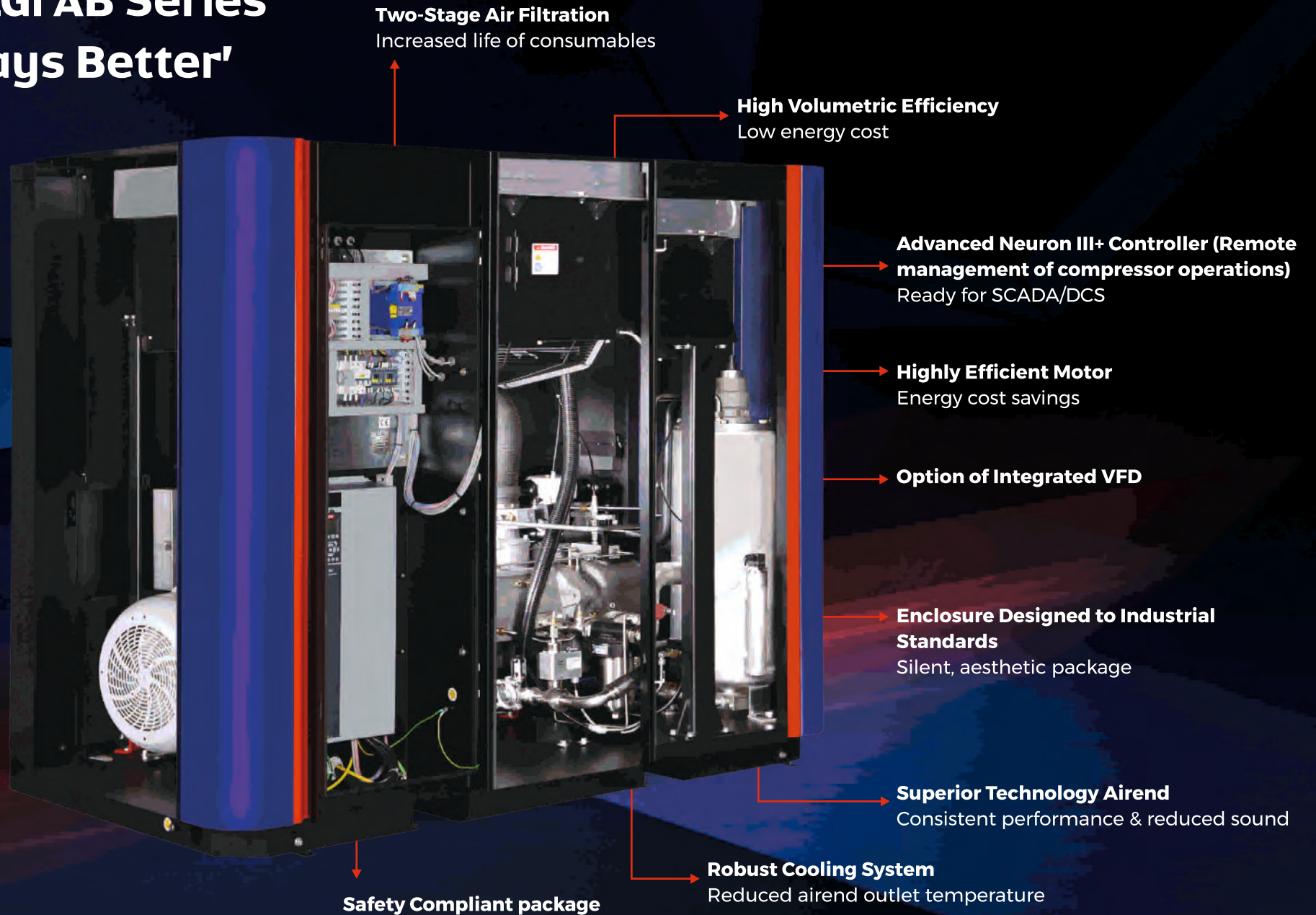



ENERGY SAVINGS

Highly efficient air end

ELGi's air ends are equipped with in-house developed η -V profile rotors, with 4/5 lobe combination. The rotors are designed to run at optimum speeds.

This unique design reduces pressure losses and increases efficiency. The rotors ensure energy efficient compressed air supply for all demanding applications.

- Precise rotor clearances for best-in-class energy efficiency.
- Low operating speed for long life, low maintenance and low sound level.
- Complies with applicable safety standards.



EFFICIENT SEPARATION

Efficient air-water separation with WSBIC (3 stages)

ELGi has applied unique WSBIC process (Water separation by Impact and Centrifugal Action) which enables efficient separation of air and water with minimum pressure drop. The method enables separation of water in three stages increasing the life of the separator element.



MOISTURE FREE AIR

99% Water Free

Depending on the humidity level of inlet air, bulk water remains in compressed air at varying levels and causes corrosion of piping, end tools, machinery and valves. AB Series air compressors have a custom-designed centrifugal type moisture separator with an automatic drain.

This comes as a part of the package at no extra cost and removes over 99% of bulk water from the compressed air, resulting in corrosion free, longer life of end use equipments and less load on the dryer.



SAFETY AND PROTECTION

AB series compressors are designed and perfected to ensure highest level of safety for

- Pressure regulating valve
- High pressure
- High temperature
- Pressure relief valve
- Phase order and single phase

Advanced Controller



PERFORMANCE CONTROL SYSTEM

- VFD Parameter (Power, Hour Meter Reading, Frequency, Ampere, Voltage)
- Read out and Closed Loop control
- Selectable analog output (Pressure/ Temperature/ Dew point) for Distributed control system integration.
- Controlled Drain System

REMOTE MONITORING

- DCS (MODBUS RTU/RS 485): controller is enabled to synchronize with distributed control system - control of compressor from control panel of customer
- SCADA : compressor control through PC with remote monitoring by supervisory control and data acquisition process

REPORTS

- Cumulative Report (Run hours, load hours, unload hours, stop hours, fault hours and remaining air filter change time, water separator change time, oil change time & re-grease time).
- Detail Report - Previous 15 days (Load hours, unload hours, stop hours, fault hours, and number of times machine stopped due to standby)
- Fault Report - (Previous 99 faults in chronological order with real time stamping and type of fault)

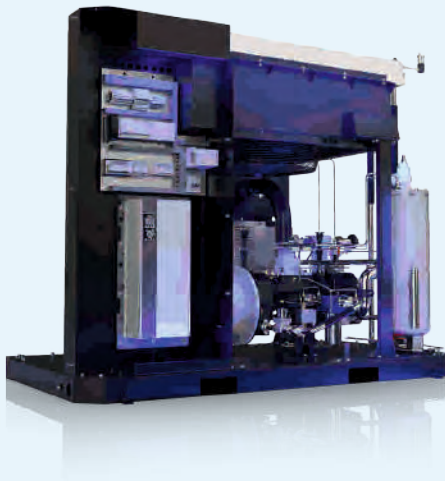

COOL AIR

Efficient air cooling

The cooling system with fans and larger cooling surface area enhances the cooling of hot air. The fan motor uses significantly low power. The integrated fan-motor assembly maintains low temperature thereby increasing life of the motor. Smart cooling system design enables easy maintenance and ducting.



REDUCED STARTING LOAD

Intake valve system

The new generation intake valve with integrated blow down unit, solenoid controls and actuators is designed for low losses.

Intake valve optimally controls the compressor capacity during startup reducing the no-load power. This optimal capacity control results in direct savings on power consumption.

Air - Water Flow Circuit

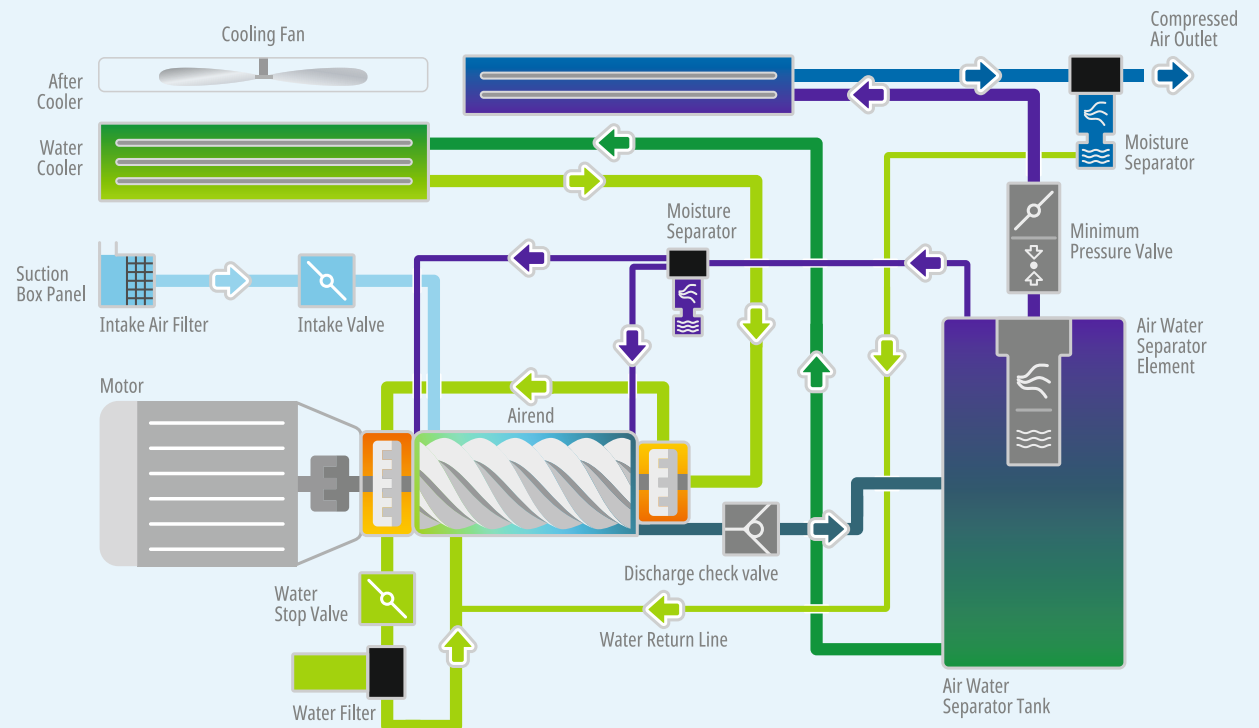
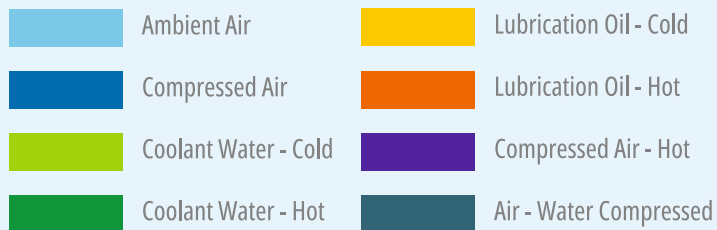

Special Features of AB Series

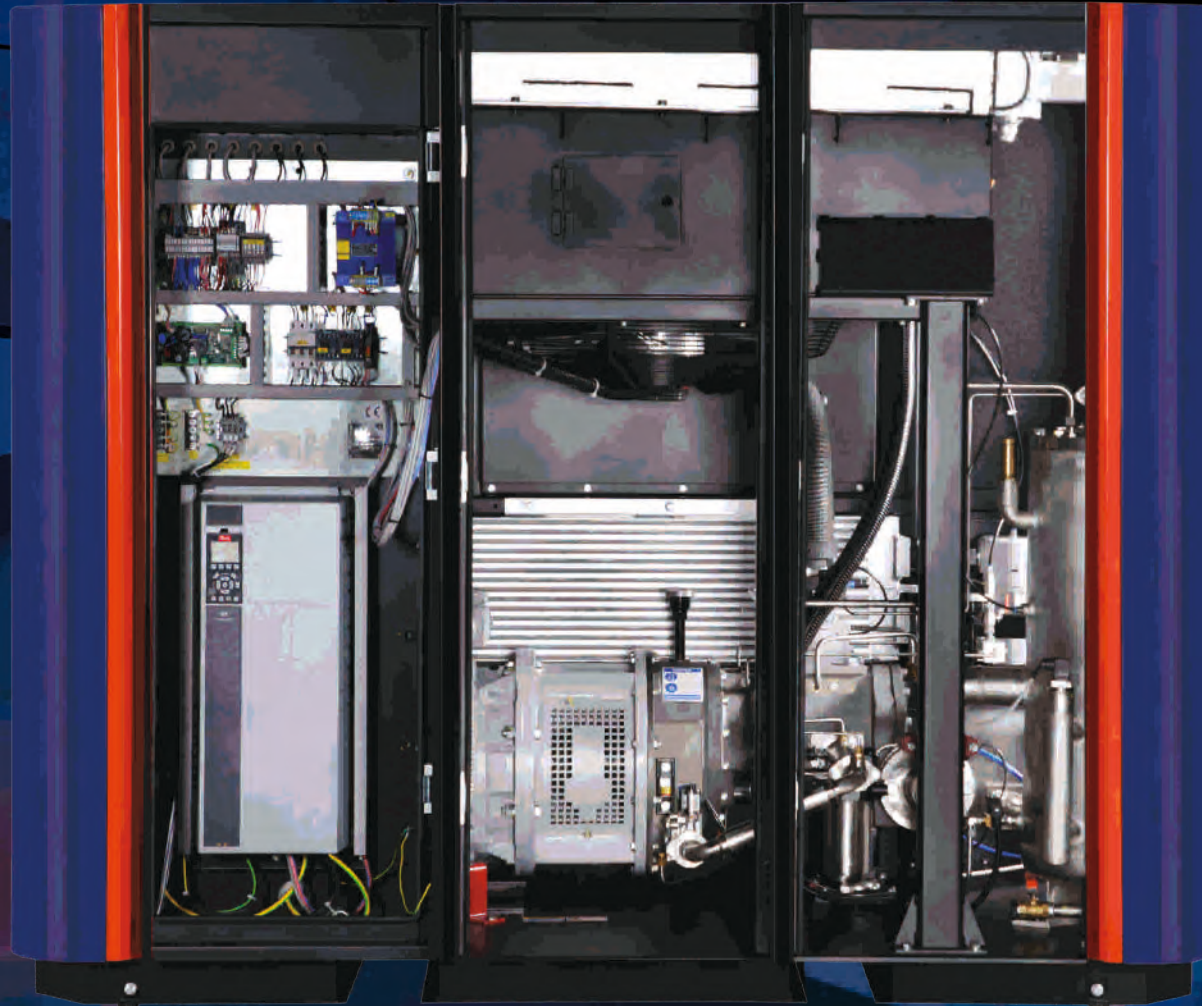



STAINLESS STEEL MATERIAL W/COATING

ELGi machines use **FDA approved** stainless steel with **proprietary coating** which eliminates any chances of corrosion. Other compressors have polymer rotors which has a significantly lower life.



USAGE OF ROLLER BEARINGS

ELGi uses roller bearings and not hydrodynamic bearings. Hydrodynamic bearings require additional water pumping circuit to pressurize these bearings. This increases power consumption in both loaded & unloaded conditions. Roller bearings eliminates these requirements and **reduces power consumption**. They are also a **proven technology** which is widely used and easy to maintain / replace.



NO RO FILTERS IN THE SYSTEM

Other compressor manufacturers either have an open-loop circuit or auxiliary water circuit for bearings & cooling. To maintain the quality of water these compressors have a RO purifier in the water inlet line. On the other hand, ELGi machines have a **closed loop water circuit** which eliminates the need for a RO system. This **reduces power & maintenance cost** for our customers.



FOOD GRADE APPROVED ANODIZED ALUMINIUM HOUSING

ELGi compressors have a **food grade approved** anodized aluminium housing that helps in inhibiting any microbiological growth.



3-LAYER SEALING

Compared to conventional dry screw compressors, the Always Better Series compressors have **3 layer sealing** for **absolute sealing and peace of mind** for our customers - gearcase side for oil sealing; air side seal on airends and redundant seals in between. This system offers absolute sealing & peace of mind to customers.



AUTO-WATER REPLENISHMENT

ELGi AB Series compressors reuse condensate water to top up water circuit. The level switch in the tank drains excess water. This ensures **fresh clean water being auto replenished** thereby avoiding the need for any open-loop requirement or water filtration/treatment at water inlet line into the compressor.



IMPROVED DRYER PERFORMANCE

Elgi AB series compressors have low airend discharge temperature and better moisture separation. This results in better **Dew Point management with Dryer**.

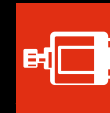

NON-CONTACT TYPE ROTORS

The rotors in the ELGi compressors do not touch ensuring **consistent performance** across the product life cycle. This creates **lesser noise & vibration**.

BENEFITS

How can the all new AB series benefit your business?

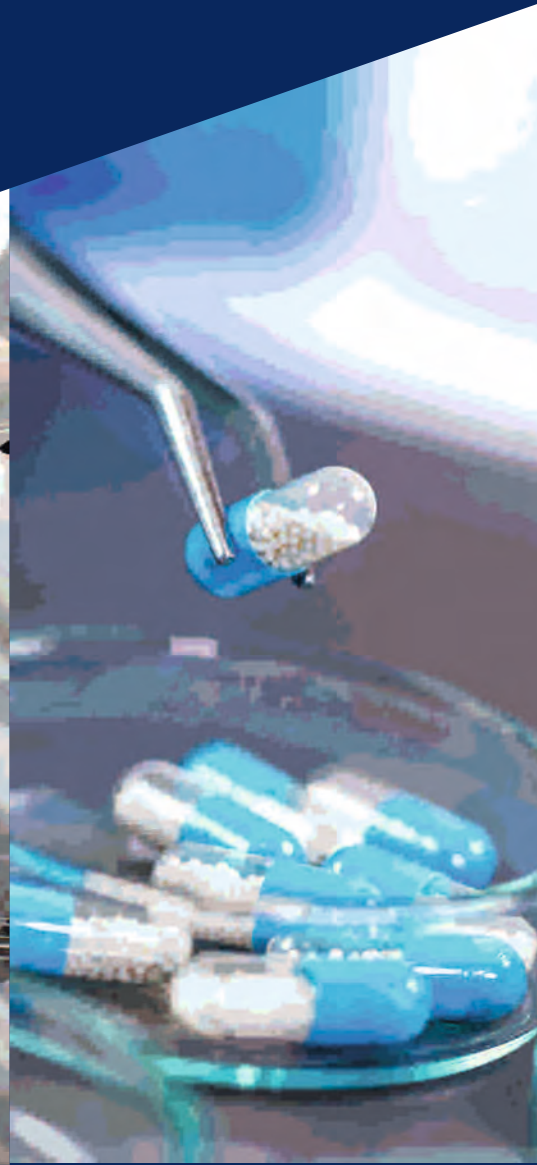

**REDUCED COST OF OWNERSHIP**

Energy cost amounts to approximately 70% of a compressors running cost. AB series compressors offer optimized pressure & volume with reduced load on-air treatment equipment.

**ENVIRONMENT FRIENDLY**

The compressed air from the package is absolutely pure with zero oil or any form of contaminant. The condensate from the compressor has clean water without any oil, making it virtually safe for reuse eliminating the need for any filter or Reverse osmosis water separator.

**REDUCED RISK OF CONTAMINATION**

The FDA has approved ELGi AB compressors series to be contaminant free as it has a proprietary coating combined with FDA approved material and closed-loop self-replenishing water circuit.

This eliminates any chance of corrosion or contaminant formation making these compressors ideal for applications where any form of oil or contaminants are not allowed.

**LOWER MAINTENANCE COST**

The efficient rotors with best in class performance, single-stage operation, low operation speed and application-oriented design, lowers overall maintenance.

**NO MICROBIOLOGICAL CONTAMINANT**

AB series compressors discharge air with no microbiological containment, complying with ISO 8573-7 standard.

KEY HIGHLIGHTS**SUPERIOR AIREND TECHNOLOGY WITH HIGH VOLUMETRIC EFFICIENCY**

Low Energy Cost

ROBUST COOLING SYSTEM

Reduced air outlet temperature

ENCLOSURE DESIGNED TO INDUSTRIAL STANDARDS

Silent, Aesthetic, Safety Compliant package

HIGHLY EFFICIENT MOTOR

Energy cost savings

ADVANCED NEURON III+ CONTROLLER

(Remote management of compressor operations)
Ready for SCADA/DCS

TWO STAGE AIR FILTRATION

Increased life of consumables



- Product – CE certified
- Air Quality – Class “O” per ISO:8573(P-2):2007
- Product Performance – ISO 1217:2009
- Pressurized components – ASME “U” stamping (USA); PED (EU); Work Cover/ Plant Design Registration (Australia); DOSH (Malaysia)
- Electricals – UL & CE certified
- Water Quality – IS:10500-2012
- Materials & processes – FDA approved per EU directive EC 1935/2004
- Air Quality for Microbial content – ISO:8573-7

CERTIFICATIONS

SEVEN COMPELLING REASONS WHY YOU SHOULD CHOOSE ELGI COMPRESSORS

BEST-IN-CLASS LIFE CYCLE COST | UPTIME GUARANTEED | ELGi TECHNICAL EDGE |
RELIABILITY | BEST-IN-CLASS WARRANTY | GLOBAL SERVICE NETWORK | PROVEN RESULTS

Energy Saving - The CONSERVE Way

The In-Built ELGi CONSERVE variable frequency drive (VFD) matches compressor output with demand by varying motor speed. The power consumption reduces in line with the reduction in demand. This helps in eliminating the frequent load-unload cycle and as a result, saves energy.

A fixed speed compressor operates on a load unload band of at least 10 psi / 0.68 bar around the working pressure whereas with ELGi VFD, compressor can be operated within a band of 2 psi / 0.14 bar.

Since the compressor is not operated above higher than working pressure requirements, there is substantial energy saving. For every 2 psi / 0.14 bar reduction in operating pressure, there is 1% power saving.

In a fixed speed compressor with Star-Delta starter, starting current is as high as three times the full

load current (FLC). With ELGi VFD, starting current is less than the FLC. This helps to avoid using heavy rated components like fuses, MCCB, cable size, generator rating and isolators.

ADVANTAGES:

ELECTRICAL:

- Low starting current
- High efficiency
- Improved power factor
- Reduced maximum demand

MECHANICAL:

- Minimum maintenance
- Reduced mechanical wear
- Smooth start
- Smooth control



TECHNICAL SPECIFICATIONS | AB SERIES OIL FREE SCREW AIR COMPRESSORS
50Hz Fixed Speed

Model	Nominal Power		Working Pressure		Free Air Delivery		Weight	Noise Level	Dimensions (LxWxH)	
	50Hz	kW	HP	bar	psi	m ³ /min	cfm	Kg	db(A)	(mm)
AB 11		11	15	7	100	1.44	51	1040	72	1985 X 1190 X 1615
		11	15	8	115	1.19	42	1040	72	1985 X 1190 X 1615
		11	15	9	125	1.1	39	1040	72	1985 X 1190 X 1615
		11	15	10	150	0.85	30	1040	72	1985 X 1190 X 1615
AB 15		15	20	7	100	2.38	84	1050	72	1985 X 1190 X 1615
		15	20	8	115	2.1	74	1050	72	1985 X 1190 X 1615
		15	20	9	125	1.93	68	1050	72	1985 X 1190 X 1615
		15	20	10	150	1.59	56	1050	72	1985 X 1190 X 1615
AB 18		15	20	12	175	0.96	34	1050	72	1985 X 1190 X 1615
		18	25	7	100	3	106	1125	72	1985 X 1190 X 1615
		18	25	8	115	2.72	96	1125	72	1985 X 1190 X 1615
		18	25	9	125	2.41	85	1125	72	1985 X 1190 X 1615
		18	25	10	150	2.04	72	1125	72	1985 X 1190 X 1615
AB 22		18	25	12	175	1.44	51	1125	72	1985 X 1190 X 1615
		22	30	7	100	3.54	125	1145	72	1985 X 1190 X 1615
		22	30	8	115	3.14	111	1145	72	1985 X 1190 X 1615
		22	30	9	125	2.83	100	1145	72	1985 X 1190 X 1615
		22	30	10	150	2.55	90	1145	72	1985 X 1190 X 1615
AB 30		22	30	12	175	1.78	63	1145	72	1985 X 1190 X 1615
		30	40	7	102	5.1	180	1494	72	2330 X 1241 X 1865
		30	40	8	116	4.5	160	1494	72	2330 X 1241 X 1865
		30	40	9	130	4.0	142	1494	72	2330 X 1241 X 1865
		30	40	10	145	3.8	133	1494	72	2330 X 1241 X 1865
AB 37		37	50	7	102	6.1	216	1560	72	2330 X 1241 X 1865
		37	50	8	116	5.7	200	1560	72	2330 X 1241 X 1865
		37	50	9	130	4.9	174	1560	72	2330 X 1241 X 1865
		37	50	10	145	4.6	162	1560	72	2330 X 1241 X 1865
		37	50	12	175	3.5	125	1560	72	2330 X 1241 X 1865
AB 45		45	60	7	102	7.3	257	1582	72	2330 X 1241 X 1865
		45	60	8	116	6.5	230	1582	72	2330 X 1241 X 1865
		45	60	9	130	5.9	208	1582	72	2330 X 1241 X 1865
		45	60	10	145	5.5	195	1582	72	2330 X 1241 X 1865
		45	60	12	175	4.6	161	1582	72	2330 X 1241 X 1865

Free Air Delivery (FAD) are tested as per ISO 1217 : 2009 - Annex C | FAD indicated is for the full package measured at the outlet | All mentioned packages are air cooled models only. | Weight indicated is approximate and actual can vary | Displayed here is the standard range. For customized packages with different voltages, medium and high voltage motor, pressure variants please contact our nearest sales office |

* Due to continuous improvements, specifications are subject to change without prior notice

TECHNICAL SPECIFICATIONS | AB SERIES OIL FREE SCREW AIR COMPRESSORS
50Hz Fixed Speed

Model	Nominal Power		Working Pressure		Free Air Delivery		Weight	Noise Level	Dimensions (LxWxH)
	50Hz	kW	HP	bar	psi	m ³ /min			
AB 55	55	75	7	102	9.6	340	3101	75	3045 X 1870 X 1982
	55	75	8	116	8.6	304	3101	75	3045 X 1870 X 1982
	55	75	9	130	7.6	268	3101	75	3045 X 1870 X 1982
	55	75	10	145	7.3	258	3101	75	3045 X 1870 X 1982
	55	75	12	175	5.6	199	3101	75	3045 X 1870 X 1982
AB 75	75	100	7	102	12.5	440	3255	75	3045 X 1870 X 1982
	75	100	8	116	11.2	397	3255	75	3045 X 1870 X 1982
	75	100	9	130	10.3	365	3255	75	3045 X 1870 X 1982
	75	100	10	145	9.7	343	3255	75	3045 X 1870 X 1982
	75	100	12	175	8.2	291	3255	75	3045 X 1870 X 1982
AB 90	90	125	7	102	13.7	485	3292	75	3045 X 1870 X 1982
	90	125	8	116	12.5	440	3292	75	3045 X 1870 X 1982
	90	125	9	130	11.6	410	3292	75	3045 X 1870 X 1982
	90	125	10	145	11	390	3292	75	3045 X 1870 X 1982
AB 110	110	150	7	102	15.9	560	3425	75	3045 X 1870 X 1982
	110	150	8	116	15.0	529	3425	75	3045 X 1870 X 1982
	110	150	9	130	13.6	480	3425	75	3045 X 1870 X 1982
	110	150	10	145	12.5	440	3425	75	3045 X 1870 X 1982

Free Air Delivery (FAD) are tested as per ISO 1217 : 2009 - Annex C | FAD indicated is for the full package measured at the outlet | All mentioned packages are air cooled models only. | Weight indicated is approximate and actual can vary | Displayed here is the standard range. For customized packages with different voltages, medium and high voltage motor, pressure variants please contact our nearest sales office |

* Due to continuous improvements, specifications are subject to change without prior notice

**TECHNICAL SPECIFICATIONS | AB SERIES OIL FREE SCREW AIR COMPRESSORS
50Hz VFD**

Model	Nominal Power		Working Pressure		Free Air Delivery		Weight	Noise Level	Dimensions (LxWxH)
	50Hz	kW	HP	bar	psi	m ³ /min	cfm	Kg	db(A)
AB 11V	11	15	7	100	1.14-1.44	40-51	1040	72	1985 X 1190 X 1615
	11	15	8	115	1.05-1.19	37-42	1040	72	1985 X 1190 X 1615
AB 15V	15	20	7	100	1.23-2.38	43-84	1070	72	1985 X 1190 X 1615
	15	20	8	115	1.18-2.1	41-74	1070	72	1985 X 1190 X 1615
	15	20	9	125	1.12-1.93	40-68	1070	72	1985 X 1190 X 1615
AB 18V	15	20	10	150	1.03-1.59	36-56	1070	72	1985 X 1190 X 1615
	18	25	7	100	1.23-3.0	43-106	1150	72	1985 X 1190 X 1615
	18	25	8	115	1.19-2.72	42-96	1150	72	1985 X 1190 X 1615
	18	25	9	125	1.12-2.41	39-85	1150	72	1985 X 1190 X 1615
AB 22V	18	25	10	150	1.06-2.04	37-72	1150	72	1985 X 1190 X 1615
	18	25	12	175	0.84-1.44	29-51	1150	72	1985 X 1190 X 1615
	22	30	7	100	1.26-3.54	44-125	1170	72	1985 X 1190 X 1615
	22	30	8	115	1.19-3.14	42-111	1170	72	1985 X 1190 X 1615
AB 30V	22	30	9	125	1.10-2.83	39-100	1170	72	1985 X 1190 X 1615
	22	30	10	150	1.07-2.55	38-90	1170	72	1985 X 1190 X 1615
	22	30	12	175	0.90-1.78	32-63	1170	72	1985 X 1190 X 1615
	30	40	7	102	3.49-5.09	123-180	1518	72	2330 X 1241 X 1865
	30	40	8	116	3.51-4.47	124-160	1518	72	2330 X 1241 X 1865
AB 37V	30	40	9	130	3.17-4.02	112-142	1518	72	2330 X 1241 X 1865
	30	40	10	145	1.86-3.76	66-133	1518	72	2330 X 1241 X 1865
	37	50	7	102	3.63-6.11	128-216	1620	72	2330 X 1241 X 1865
	37	50	8	116	3.54-5.66	125-200	1620	72	2330 X 1241 X 1865
	37	50	9	130	3.17-4.93	112-174	1620	72	2330 X 1241 X 1865
	37	50	10	145	3.51-4.59	124-162	1620	72	2330 X 1241 X 1865
AB 45V	37	50	12	175	2.77-3.17	98-125	1620	72	2330 X 1241 X 1865
	45	60	7	102	3.31-7.22	117-257	1631	72	2330 X 1241 X 1865
	45	60	8	116	3.25-6.51	115-230	1631	72	2330 X 1241 X 1865
	45	60	9	130	3.17-5.89	112-208	1631	72	2330 X 1241 X 1865
	45	60	10	145	3.48-5.38	123-195	1631	72	2330 X 1241 X 1865
	45	60	12	175	2.86-4.56	101-161	1631	72	2330 X 1241 X 1865

Free Air Delivery (FAD) are tested as per ISO 1217 : 2009 - Annex E | FAD indicated is for the full package measured at the outlet | All mentioned packages are air cooled models only. | Weight indicated is approximate and actual can vary | Displayed here is the standard range. For customized packages with different voltages, medium and high voltage motor, pressure variants please contact our nearest sales office |

* Due to continuous improvements, specifications are subject to change without prior notice

TECHNICAL SPECIFICATIONS | AB SERIES OIL FREE SCREW AIR COMPRESSORS 50Hz VFD

Model	Nominal Power		Working Pressure		Free Air Delivery		Weight	Noise Level	Dimensions (LxWxH)
	50Hz	kW	HP	bar	psi	m ³ /min			
AB 55V	55	75	7	102	6.82-9.63	241-340	3150	75	3045 X 1870 X 1982
	55	75	8	116	6.68-8.6	236-304	3150	75	3045 X 1870 X 1982
	55	75	9	130	6.48-7.59	229-268	3150	75	3045 X 1870 X 1982
	55	75	10	145	6.11-7.3	216-258	3150	75	3045 X 1870 X 1982
	55	75	12	175	5.04-5.61	178-198	3150	75	3045 X 1870 X 1982
AB 75V	75	100	7	102	6.99-12.45	247-440	3277	75	3045 X 1870 X 1982
	75	100	8	116	7.13-11.24	252-397	3277	75	3045 X 1870 X 1982
	75	100	9	130	6.60-10.34	233-365	3277	75	3045 X 1870 X 1982
	75	100	10	145	6.25-9.71	221-343	3277	75	3045 X 1870 X 1982
	75	100	12	175	4.87-8.21	172-290	3277	75	3045 X 1870 X 1982
AB 90V	90	125	7	102	6.96-13.7	245-485	3390	75	3045 X 1870 X 1982
	90	125	8	116	7.22-12.46	255-440	3390	75	3045 X 1870 X 1982
	90	125	9	130	6.51-11.61	230-410	3390	75	3045 X 1870 X 1982
	90	125	10	145	6.54-11.04	231-390	3390	75	3045 X 1870 X 1982
AB 110V	110	150	7	102	6.86-15.68	245-560	3523	75	3045 X 1870 X 1982
	110	150	8	116	7.14-14.81	255-529	3523	75	3045 X 1870 X 1982
	110	150	9	130	6.44-13.44	230-480	3523	75	3045 X 1870 X 1982
	110	150	10	145	6.47-12.32	231-440	3523	75	3045 X 1870 X 1982

Free Air Delivery (FAD) are tested as per ISO 1217 : 2009 - Annex E | FAD indicated is for the full package measured at the outlet | All mentioned packages are air cooled models only. | Weight indicated is approximate and actual can vary | Displayed here is the standard range. For customized packages with different voltages, medium and high voltage motor, pressure variants please contact our nearest sales office |

* Due to continuous improvements, specifications are subject to change without prior notice



CII AWARD

The ELGi AB 'Always Better' series, won the CII Design Excellence Award in the Industrial Design, capital goods category, earlier this year. The CII Design Excellence Awards, endorsed by the India Design Council, acknowledge and celebrate design and innovation in India, while aiming to create new paradigms of design and promoting a unique amalgamation of traditional and contemporary design. The award was granted based on innovation, originality, distinctiveness, use of new materials & technology & user friendliness.

DEMING QUALITY AWARD

JUSE in Japan recognizes organizations that follow principles of total quality management in driving organization culture & business results. ELGi is now the first globally established industrial air compressor manufacturer to be awarded the Deming prize for excellence in Total Quality Management.

CAGI MEMBERSHIP

ELGi is a member of the CAGI which is the united voice of the compressed air industry, serving as the unbiased authority on technical, educational, promotional and other matters that affect the industry. Members comply with norms of performance testing & publishing.

STANDARD UPTIME ASSURANCE

ELGi has a robust service network in every region it operates. Our uptime assurance ensures units are always running for our customers.

48-HOUR PARTS AVAILABILITY

ELGi distributors stock high volumes of replacement filters and parts. However, if they don't have a specific part available, we'll ship it to you within 48* hours.

COMPETITIVE PARTS PRICING

We offer genuine ELGi replacement parts and consumables (filters, oil etc.,) as it is key to protecting your AB series compressor and providing maximum uptime.

LOANER MACHINES

If your compressor goes down, we'll have it repaired* within 48 -hours or we can offer you the use of a loaner machine while yours is being repaired.

CUSTOMER HOTLINE

When you have service questions, you want to be able to speak to a person, not a machine. You also want that person to be local and knowledgeable. That's why our customer hotline is staffed by industry professionals who know our products, and your business.

* Subject to conditions and may vary for different countries



ELGi[®]
Always Better.